

CAD FILE:

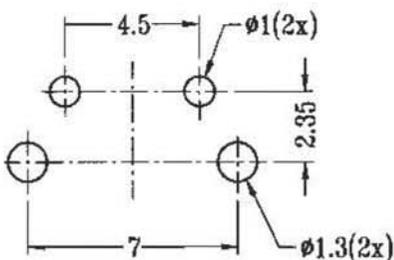

P.C.B LAYOUT
BOTTOM VIEW

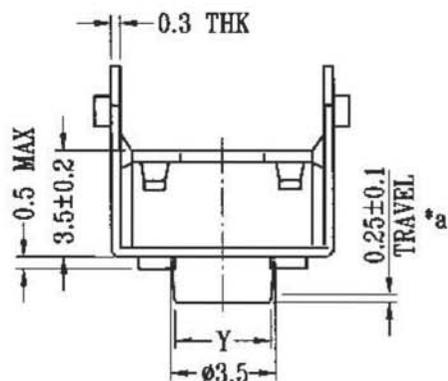
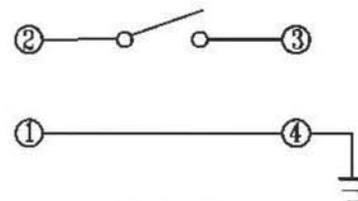

SCHEMATIC

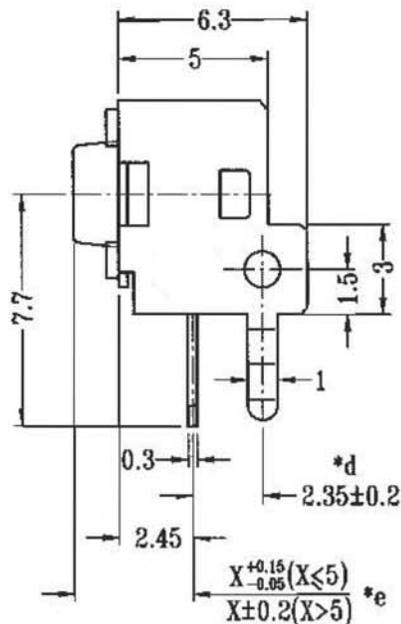
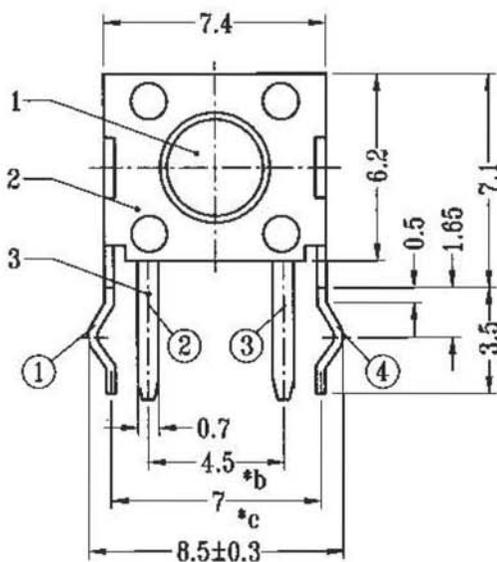

TC-A210-002	TC0111	15.85	Ø2.7
TC-0210-002	TC0110	12.35	Ø3.2
TC-G209-002	TCG109	12.85	Ø3.1
TC-B209-002	TCB109	9.85	Ø3.2
TC-A209-002	TC0107	7.35	Ø3.1
TC-0209-002	TCA109	11.85	Ø3.3
TC-0208-002	TC0105	6.15	Ø3.3
TC-A207-002	TCA107	7.85	Ø3.1
TC-0207-002	TC0109	11.35	Ø3.0
TC-0206-002	TC0106	6.85	Ø3.3
TC-B205-002	TCB108	9.35	Ø3.2
TC-0205-002	TC0108	8.35	Ø3.3
TC-0204-002	TC0104	5.85	Ø3.3
TC-G203-002	TCG103	4.35	Ø3.4
TC-A203-002	TCA103	4.85	Ø3.4
TC-0203-002	TC0103	3.85	Ø3.4
TC-0202-002	TC0102	3.15	Ø3.5
TC-0201-002	TC0101	3.05	Ø3.5
MODEL NO.	KNOB TYPE	X	Y

注：“*”表示关键尺寸(5个).

NO.	PARTS	MATERIALS	Q'TY	FINISH	TOLERANCE UNLESS SPECIFIED	ISSUE	DATE	DESCRIPTIONS OF REVISION	APPD.
8					WITHIN 1.5mm : ±0.1mm			产品增加P.C.B尺寸	
7					OVER 1.5mm : ±0.2mm				
6									
5									
4	CONTACT	PBS C5210R-EH	1	Ag CLAD					
3	CASE	NYLON+F.G/BRASS STRIP	1	BLACK/Ag PLATED OVER Ni PLATED					
2	COVER	STEEL STRIP	1	Sn PLATED					
1	KNOB	NYLON+F.G	1	BLACK/RED/WHITE					
					TITLE : TACT SWITCH		UNIT : mm	DRWG NO.: TT-DR-TC0201002-00	
					MODEL: TC-0201-002~0210-002		SCALE: 4:1	DWN.	曾小伟
					淮洋有限公司 HUAI YANG CO., LTD.		CHK'D	2014-12-9	
							APPD.	2014.12.9	

淮洋有限公司 HUI YANG CO., LTD. www.hy1688.com.tw		文件编号	SF-SP-3111
		发布日期	2007 年 11 月 26 日
SPECIFICATION 规格书		第 B 版	第 1 页 共 3 页
MODEL NO. 产品名称 : TC-0201~0210 TC-A209			
DRAWN 制订		周燕柳	APPD. 审批 
1. RATING (額定值) : DC 12V 50mA			
2. ELECTRICAL CHARACTERISTICS (电气性能规格)			
ITEM 项目		TEST CONDITIONS 测试条件	PERFORMANCE 规格
2.1	CONTACT RESISTANCE 接触电阻	MEASURED AT 1KHz SMALL CURRENT (100mA OR LESS) 在 1KHz 微小电流 (100mA 以下) 测试。	100mΩ MAX. 100 毫歐以下。
2.2	INSULATION RESISTANCE 絕緣電阻	APPLY A VOLTAGE OF 100V DC FOR 1 MIN. TO FOLLOWING PORTIONS AFTER WHICH MEASUREMENT SHALL BE MADE. (1) BETWEEN BODY AND CONDUCTOR. (2) BETWEEN CONDUCTORS NOT TO BE CONTACT. 輸入 100V DC 電壓 1 分鐘, 按以下接觸方法測試: (1) 接觸端子之間. (2) 膠座體與排腳之間.	100MΩ MIN. 100 兆歐以上。
2.3	DIELECTRIC STRENGTH 耐電壓	AC 250V rms (50-60Hz) FOR 1 MIN TRIP CURRENT: 0.5 mA (1) BETWEEN TERMINALS. (2) BETWEEN INDIVIDUAL TERMINAL AND FRAME. 輸入 AC 250V (50-60Hz) 電壓, 1 分鐘感度電流為 0.5mA, 按以下接觸方法測試: (1) 排腳相互之間 (2) 排腳與外殼之間	WITHOUT DAMAGE TO PARTS ARCING OR BREAKDOWN ETC. 沒有絕緣破壞等異常。
3. MECHANICAL CHARACTERISTICS (機械性能规格)			
ITEM 項目		TEST CONDITIONS 測試條件	PERFORMANCE 規格
3.1	OPERATING FORCE 作動力		見第三頁
3.2	TERMINAL STRENGTH 端子強度	A STATIC LOAD OF (300 gf) SHALL BE APPLIED TO THE TIP OF THE TERMINAL FOR 1 MIN IN ANY DIRECTION. 在任意一個方向的先端加上 (300 gf) 力度測試, 時間為 1 分鐘。	MECHANICAL AND ELECTRICAL CHARACTERISTICS SHALL BE SATISFIED WITHOUT DAMAGE OR EXCESSIVE LOOSENESS OF ACTUATOR. 在端子中沒有裂開、鬆動等異常, 滿足于機械、電器性能。

淮洋有限公司 HUI YANG CO., LTD. www.hy1688.com.tw		文件编号	SF-SP-3111									
		发布日期	2007 年 11 月 26 日									
SPECIFICATION 规格书		第 B 版	第 2 页 共 3 页									
3.3	STANDARD ATMOSPHERIC CONDITIONS 測試標準狀態	UNLESS OTHERWISE SPECIFIED. THE STANDARD RANGE OF ATMOSPHERIC CONDITIONS FOR MAKING MEASUREMENTS AND TESTS ARE AS FOLLOWS: (1) AMBIENT TEMPERATURE: 5°C TO 35°C (2) RELATIVE HUMIDITY : 45% TO 85% (3) AIR PRESSURE : 80Kpa TO 106Kpa 在沒有指定的情況下測試溫度、濕度、氣壓如下: (1) 溫度為 5°C~35°C. (2) 濕度為 45%~85%. (3) 氣壓為 80Kpa~106Kpa.										
3.4	PRACTICAL TEMPERATURE RANG 使用溫度範圍	-16°C~+60°C. 在-16°C~+60°C溫度內使用.										
4. DURABILITY (耐久性)												
ITEM 項目		TEST CONDITIONS 测试条件	PERFORMANCE 规格									
4.1	SOLDERABILITY TEST 可焊性試驗	THE TOP OF THE TERMINALS SHALL BE DIPPED 2mm IN THE SOLDER BATH OF 230±10°C FOR 3±0.5 SECONDS. 端子頂部被浸入錫焊池中 2mm 深，溫度為 230±10°C，時間為 3±0.5 秒.	THE AREA OF SOLDERING SHOULD BE OVER 75%. 焊接面積要有 75% 以上。									
4.2	RESISTANCE TO SOLDERING HEAT TEST 耐焊性試驗	(1). TEMPERATURE AND IMMERSING TIME 溫度及浸錫時間 <table border="1"> <thead> <tr> <th></th> <th>TEMPERATURE 溫度(°C)</th> <th>TIME 時間(s)</th> </tr> </thead> <tbody> <tr> <td>DIP SOLDERING 浸 錫</td> <td>260±5</td> <td>3±1</td> </tr> <tr> <td>MANUAL SOLDERING 手 焊</td> <td>360±10</td> <td>3±1</td> </tr> </tbody> </table> (2). IMMERSION DEPTH: IMMERSION DEPTH UP TO THE SURFACE OF THE BOARD THICKNESS OF PRINTED WIRING BOARD 1.6mm . 浸錫深度: 浸錫深度至基板(PCB)表面, 基板厚度为 1.6mm。 (3). WAVE SOLDERING 波峰焊 (A) 260±5°C 5 SEC. MAX. (B) PREHEAT TIME SHALL BE 30 SECONDS MAX. AT 100°C MAX. 預熱溫度 100°C 以下, 30 秒以內完成.		TEMPERATURE 溫度(°C)	TIME 時間(s)	DIP SOLDERING 浸 錫	260±5	3±1	MANUAL SOLDERING 手 焊	360±10	3±1	THERE SHALL BE NO DEFORMATION OR CRACKS IN MOLDED PART. 外觀無異常, 滿足于機械、電器性能。
	TEMPERATURE 溫度(°C)	TIME 時間(s)										
DIP SOLDERING 浸 錫	260±5	3±1										
MANUAL SOLDERING 手 焊	360±10	3±1										
4.3	LIFE TEST 壽命試驗	WITHOUT LOAD: AN ACTUATOR SHALL BE SUBJECT TO 100,000 CYCLES AT A SPEED OF 60 CYCLES FOR 1 MIN. 無負荷: 操作者以每分鐘 60 次的頻率作 100,000 回之無負荷測試.	(1) CONTACT RESISTANCE SHALL BE 200mΩ MAX. (2) MECHANICAL AND ELECTRICAL CHARACTERISTICS SHALL BE SATISFIED. (1) 接觸電阻不能超于 200mΩ. (2) 其它、滿足于機械、電器性能.									

淮洋有限公司HUI YANG CO.,LTD. www.hy1688.com.tw	文件编号	SF-SP-3111
	发布日期	2007年11月26日
SPECIFICATION 规格书	第B版	第3页 共3页

ITEM 项目	TEST CONDITIONS 测试条件	PERFORMANCE 规格
4.4 HEAT TEST 耐熱試驗	<p>THE SWITCH SHALL BE STORED AT A TEMPERATURE OF 85±2°C FOR 96 HOURS AND THEN IT SHALL BE SUBJECTED TO THE CONTROLLED RECOVERY CONDITIONS FOR 1 HOUR AFTER WHICH MEASUREMENT SHALL BE MADE.</p> <p>放置在溫度 85±2°C 中測試 96 小時后,再放置正常室溫中 1 小時來測定。</p>	<p>THERE SHALL BE NO DAMAGE ON APPEARANCE. MECHANICAL AND ELECTRICAL CHARACTERISTICS SHALL BE SATISFIED.</p> <p>外觀無異常,滿足于機械、電器性能。</p>
4.5 COLD TEST 耐冷試驗	<p>THE SWITCH SHALL BE STORED AT A TEMPERATURE OF -25±3°C FOR 96 HOURS AND THEN IT SHALL BE SUBJECTED TO THE CONTROLLED RECOVER CONDITIONS FOR 1 HOUR AFTER WHICH MEASUREMENT SHALL BE MADE.</p> <p>放置在溫度 - 25±3°C 中 96 小時后,再放置常溫常濕中 1 小時來測定。</p>	
4.6 HUMIDITY TEST 潮濕試驗	<p>THE SWITCH SHALL BE STORED AT A TEMPERATURE OF 40±2°C AND A HUMIFITY OF 90% TO 96% FOR 96 HOURS, THEN THE SWITCH SHALL BE MAINTAINED AT STANDARD ATMOSPHERIC CONDITION FOR 1 Hr FOR OTHER PROCEDURES BE MADE.</p> <p>放置在 40±2°C 的相對濕度為 90~96% 環境中 96 小時后,再將樣版放在正常環境 1 小時后進行測試。</p>	

CODE	O/FORCE
T	100gf±30gf
V	130gf±30gf
X	160gf±50gf
W	170gf±50gf
Y	190gf±50gf
Z	250gf±100gf